

# W1-3D



## Gas Spring Monitor Wall Mount



### General Specifications

Supported Screen Size	≤ 43"/≤ 49" Ultrawide Monitor
VESA Standard	VESA 75 (75x75)   VESA 100 (100x100)
Maximum Monitor Weight	8 kg   17.6 lbs
Rotation	360°
Swivel	180°
Tilt	+/-90°
Distance to the Pole	8-60 cm
Material	Aluminum Alloy ADC12
Weight	1.65 kg
Colour	Black

### Shipping Information

Box Dimensions	434 (L) x 129 (W) x 85 (H) mm
Gross Weight	2150 g
SKU	AEMNT00032A
EAN	4895213700344
UPC	872767008618
Package Content	W1-3D x1 Installation Kit x1

# W1-3D

Gas Spring Monitor Wall Mount

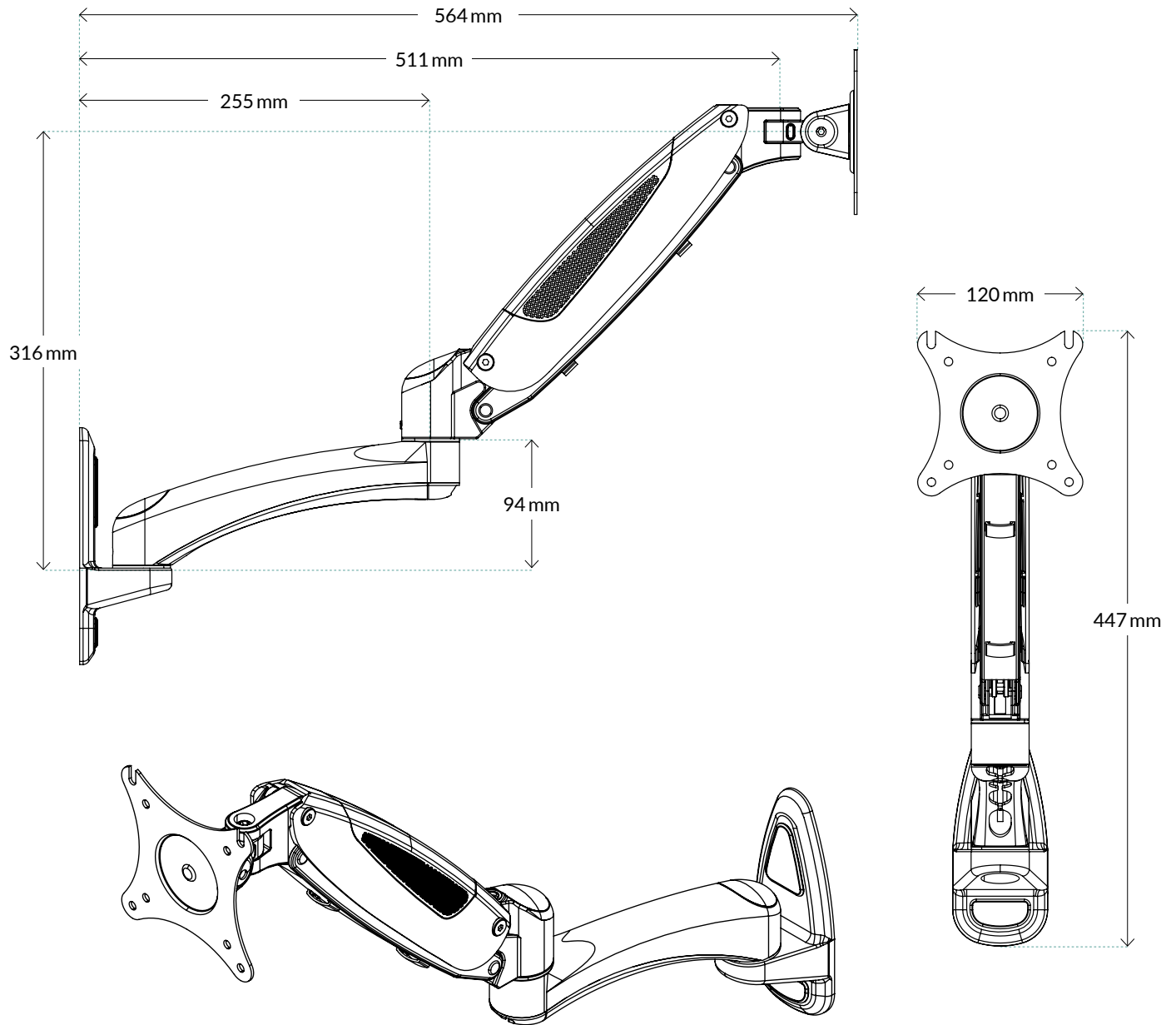

All materials are compatible with RoHS requirements.

MORE INFORMATION



MANUALS

